

# FR-E800 Series

World's smallest class inverter with high functionality.

- Up to 30HP
- SIL3 safety models
- Improved usability by supporting CC-Link IE TSN as standard
- Multi-protocol support enables switching between various types of communication networks
- Enabled flexible connection with two Ethernet ports
- The AI fault diagnosis function is used to identify the cause of a fault, enabling the fastest troubleshooting procedure
- Position and orientation controls for simple motion applications
- Enhanced predictive maintenance

- Using smartphones or tablets, you can scan the QR code on the product to access the setup information, or you can access inverters via wireless remote network with a mobile app.
- Various control methods such as Vector control (with encoder), Real sensorless vector control (without encoder), and positioning without using sensors are supported. Premium efficiency motors and PM motors are supported, enabling applications in various solutions

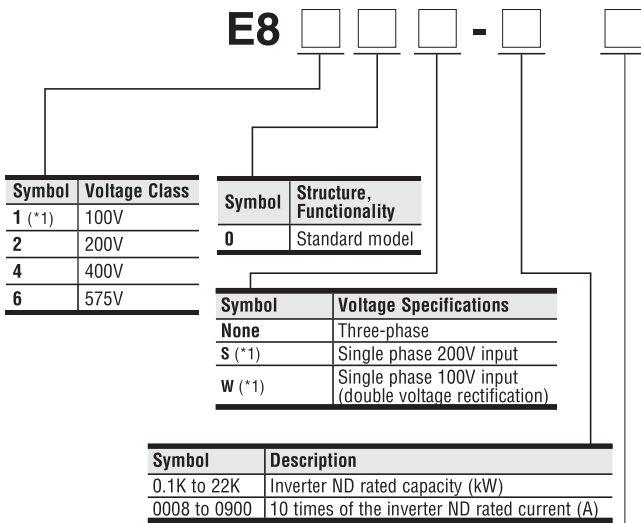

Symbol	Monitoring/Protocol Specification	Rated Frequency
-1	Pulse (terminal FM)	60Hz
-4	Voltage (terminal AM)	50Hz
-5	Voltage (terminal AM)	60Hz
PA	Protocol Group A (CC-Link IE TSN, CC-Link IE Field Network Basic, MODBUS/TCP, EtherNet/IP, and BACnet/IP)	60Hz
PB	Protocol Group B (CC-Link IE TSN, CC-Link IE Field Basic Network Basic, MODBUS/TCP, and PROFINET)	50Hz
PC (*1)	Protocol Group C (EtherCAT)	50Hz

Symbol	Circuit Board Coating
None	Without coating
-60	With coating

Symbol	Communication/Functional Safety Specification
None	RS-485 + SIL2/PLd
E	Ethernet + SIL2PLd
SCE (*1)	Ethernet + SIL3/PLe

\*1: To be released

## FR-E820S

1-Phase 240V Serial Modbus RTU	HP (ND)	AMPS (ND)
E820S-0008-5-60	1/8	0.8
E820S-0015-5-60	1/4	1.5
E820S-0030-5-60	1/2	3
E820S-0050-5-60	1	5
E820S-0080-5-60	2	8
E820S-0110-5-60	3	11

1-Phase 240V Ethernet Protocol A	HP (ND)	AMPS (ND)
E820S-0008EPA-60	1/8	0.8
E820S-0015EPA-60	1/4	1.5
E820S-0030EPA-60	1/2	3
E820S-0050EPA-60	1	5
E820S-0080EPA-60	2	8
E820S-0110EPA-60	3	11

1-Phase 240V Ethernet Protocol C	HP (ND)	AMPS (ND)
EtherCAT		
E820S-0008EPC-60	1/8	0.8
E820S-0015EPC-60	1/4	1.5
E820S-0030EPC-60	1/2	3
E820S-0050EPC-60	1	5
E820S-0080EPC-60	2	8
E820S-0110EPC-60	3	11

1-Phase 240V Safety Protocol A	HP (ND)	AMPS (ND)
E820S-0008SCEPA-60	1/8	0.8
E820S-0015SCEPA-60	1/4	1.5
E820S-0030SCEPA-60	1/2	3
E820S-0050SCEPA-60	1	5
E820S-0080SCEPA-60	2	8
E820S-0110SCEPA-60	3	11

1-Phase 240V Safety Protocol B	HP (ND)	AMPS (ND)
E820S-0008SCEPB-60	1/8	0.8
E820S-0015SCEPB-60	1/4	1.5
E820S-0030SCEPB-60	1/2	3
E820S-0050SCEPB-60	1	5
E820S-0080SCEPB-60	2	8
E820S-0110SCEPB-60	3	11

Load Rating	Overload Current Rating
Normal Duty (ND)	150% 60 seconds, 200% 3 seconds (inverse-time characteristics) at surrounding air temperature of 50°C.

## FR-E820

240V Ethernet Protocol A	HP (ND)	AMPS (ND)	AMPS (LD)
E820-0008EPA-60	1/8	0.8	1.3
E820-0015EPA-60	1/4	1.5	2
E820-0030EPA-60	1/2	3	3.5
E820-0050EPA-60	1	5	6
E820-0080EPA-60	2	8	9.6
E820-0110EPA-60	3	11	12
E820-0175EPA-60	5	17.5	19.6
E820-0240EPA-60	7.5	24	30
E820-0330EPA-60	10	33	40
E820-0470EPA-60	15	47	56
E820-0600EPA-60	20	60	69
E820-0760EPA-60	25	76	88
E820-0900EPA-60	30	90	115

3-Phase 240V Serial Modbus RTU	HP (ND)	AMPS (ND)	AMPS (LD)
E820-0008-5-60	1/8	0.8	1.3
E820-0015-5-60	1/4	1.5	2
E820-0030-5-60	1/2	3	3.5
E820-0050-5-60	1	5	6
E820-0080-5-60	2	8	9.6
E820-0110-5-60	3	11	12
E820-0175-5-60	5	17.5	19.6
E820-0240-5-60	7.5	24	30
E820-0330-5-60	10	33	40
E820-0470-5-60	15	47	56
E820-0600-5-60	20	60	69
E820-0760-5-60	25	76	88
E820-0900-5-60	30	90	115

240V Ethernet Protocol B	HP (ND)	AMPS (ND)	AMPS (LD)
E820-0008EPB-60	1/8	0.8	1.3
E820-0015EPB-60	1/4	1.5	2
E820-0030EPB-60	1/2	3	3.5
E820-0050EPB-60	1	5	6
E820-0080EPB-60	2	8	9.6
E820-0110EPB-60	3	11	12
E820-0175EPB-60	5	17.5	19.6
E820-0240EPB-60	7.5	24	30
E820-0330EPB-60	10	33	40
E820-0470EPB-60	15	47	56
E820-0600EPB-60	20	60	69
E820-0760EPB-60	25	76	88
E820-0900EPB-60	30	90	115

240V Safety Protocol A	HP (ND)	AMPS (ND)	AMPS (LD)
E820-0008SCEPA-60	1/8	0.8	1.3
E820-0015SCEPA-60	1/4	1.5	2
E820-0030SCEPA-60	1/2	3	3.5
E820-0050SCEPA-60	1	5	6
E820-0080SCEPA-60	2	8	9.6
E820-0110SCEPA-60	3	11	12
E820-0175SCEPA-60	5	17.5	19.6
E820-0240SCEPA-60	7.5	24	30
E820-0330SCEPA-60	10	33	40
E820-0470SCEPA-60	15	47	56
E820-0600SCEPA-60	20	60	69
E820-0760SCEPA-60	25	76	88
E820-0900SCEPA-60	30	90	115

240V Ethernet Protocol C	HP (ND)	AMPS (ND)	AMPS (LD)
E820-0008EPC-60	1/8	0.8	1.3
E820-0015EPC-60	1/4	1.5	2
E820-0030EPC-60	1/2	3	3.5
E820-0050EPC-60	1	5	6
E820-0080EPC-60	2	8	9.6
E820-0110EPC-60	3	11	12
E820-0175EPC-60	5	17.5	19.6
E820-0240EPC-60	7.5	24	30
E820-0330EPC-60	10	33	40
E820-0470EPC-60	15	47	56
E820-0600EPC-60	20	60	69
E820-0760EPC-60	25	76	88
E820-0900EPC-60	30	90	115

240V Safety Protocol B	HP (ND)	AMPS (ND)	AMPS (LD)
E820-0008SCEPB-60	1/8	0.8	1.3
E820-0015SCEPB-60	1/4	1.5	2
E820-0030SCEPB-60	1/2	3	3.5
E820-0050SCEPB-60	1	5	6
E820-0080SCEPB-60	2	8	9.6
E820-0110SCEPB-60	3	11	12
E820-0175SCEPB-60	5	17.5	19.6
E820-0240SCEPB-60	7.5	24	30
E820-0330SCEPB-60	10	33	40
E820-0470SCEPB-60	15	47	56
E820-0600SCEPB-60	20	60	69
E820-0760SCEPB-60	25	76	88
E820-0900SCEPB-60	30	90	115

Load Rating	Overload Current Rating
Light Duty (LD)	120% 60 seconds, 150% 3 seconds (inverse-time characteristics) at surrounding air temperature of 50°C.
Normal Duty (ND)	150% 60 seconds, 200% 3 seconds (inverse-time characteristics) at surrounding air temperature of 50°C.

**FR-E840**

480V Serial Modbus RTU	HP (ND)	AMPS (ND)	AMPS (LD)
E840-0016-5-60	1/2	1.6	2.1
E840-0026-5-60	1	2.6	3.5
E840-0040-5-60	2	4	5.5
E840-0060-5-60	3	6	6.9
E840-0095-5-60	5	9.5	11.1
E840-0120-5-60	7.5	12	17.5
E840-0170-5-60	10	17	23
E840-0230-5-60	15	23	35
E840-0300-5-60	20	30	41
E840-0380-5-60	25	38	45
E840-0440-5-60	30	44	60

480V Ethernet Protocol C	HP (ND)	AMPS (ND)	AMPS (LD)
E840-0016EPC-60	1/2	1.6	2.1
E840-0026EPC-60	1	2.6	3.5
E840-0040EPC-60	2	4	5.5
E840-0060EPC-60	3	6	6.9
E840-0095EPC-60	5	9.5	11.1
E840-0120EPC-60	7.5	12	17.5
E840-0170EPC-60	10	17	23
E840-0230EPC-60	15	23	35
E840-0300EPC-60	20	30	41
E840-0380EPC-60	25	38	45
E840-0440EPC-60	30	44	60

480V Ethernet Protocol A	HP (ND)	AMPS (ND)	AMPS (LD)
E840-0016EPA-60	1/2	1.6	2.1
E840-0026EPA-60	1	2.6	3.5
E840-0040EPA-60	2	4	5.5
E840-0060EPA-60	3	6	6.9
E840-0095EPA-60	5	9.5	11.1
E840-0120EPA-60	7.5	12	17.5
E840-0170EPA-60	10	17	23
E840-0230EPA-60	15	23	35
E840-0300EPA-60	20	30	41
E840-0380EPA-60	25	38	45
E840-0440EPA-60	30	44	60

480V Safety Protocol A	HP (ND)	AMPS (ND)	AMPS (LD)
E840-0016SCEPA-60	1/2	1.6	2.1
E840-0026SCEPA-60	1	2.6	3.5
E840-0040SCEPA-60	2	4	5.5
E840-0060SCEPA-60	3	6	6.9
E840-0095SCEPA-60	5	9.5	11.1
E840-0120SCEPA-60	7.5	12	17.5
E840-0170SCEPA-60	10	17	23
E840-0230SCEPA-60	15	23	35
E840-0300SCEPA-60	20	30	41
E840-0380SCEPA-60	25	38	45
E840-0440SCEPA-60	30	44	60

480V Ethernet Protocol B	HP (ND)	AMPS (ND)	AMPS (LD)
E840-0016EPB-60	1/2	1.6	2.1
E840-0026EPB-60	1	2.6	3.5
E840-0040EPB-60	2	4	5.5
E840-0060EPB-60	3	6	6.9
E840-0095EPB-60	5	9.5	11.1
E840-0120EPB-60	7.5	12	17.5
E840-0170EPB-60	10	17	23
E840-0230EPB-60	15	23	35
E840-0300EPB-60	20	30	41
E840-0380EPB-60	25	38	45
E840-0440EPB-60	30	44	60

480V Safety Protocol B	HP (ND)	AMPS (ND)	AMPS (LD)
E840-0016SCEPB-60	1/2	1.6	2.1
E840-0026SCEPB-60	1	2.6	3.5
E840-0040SCEPB-60	2	4	5.5
E840-0060SCEPB-60	3	6	6.9
E840-0095SCEPB-60	5	9.5	11.1
E840-0120SCEPB-60	7.5	12	17.5
E840-0170SCEPB-60	10	17	23
E840-0230SCEPB-60	15	23	35
E840-0300SCEPB-60	20	30	41
E840-0380SCEPB-60	25	38	45
E840-0440SCEPB-60	30	44	60

Load Rating	Overload Current Rating
Light Duty (LD)	120% 60 seconds, 150% 3 seconds (inverse-time characteristics) at surrounding air temperature of 50°C.
Normal Duty (ND)	150% 60 seconds, 200% 3 seconds (inverse-time characteristics) at surrounding air temperature of 50°C.

## FR-E860

### Protocol Group A

CC-Link IE TSN, CC-Link IE Field Network Basic, Modbus/TCP, EtherNet/IP, BACnet/IP

<b>E860-0017EPA-60</b>	VFD 1.7A 600V 0.75KW 1HP (ND) ETH-PA
<b>E860-0017EPA-60</b>	VFD 1.7A 600V 0.75KW 1HP (ND) ETH-PA
<b>E860-0027EPA-60</b>	VFD 2.7A 600V 1.5KW 2HP (ND) ETH-PA
<b>E860-0040EPA-60</b>	VFD 4.0A 600V 2.2KW 3HP (ND) ETH-PA
<b>E860-0061EPA-60</b>	VFD 6.1A 600V 3.7KW 5HP (ND) ETH-PA
<b>E860-0090EPA-60</b>	VFD 9.0A 600V 5.5KW 7.5HP (ND) ETH-PA
<b>E860-0120EPA-60</b>	VFD 12.0A 600V 7.5KW 10HP (ND) ETH-PA

### Protocol Group A- Safety SiI3

CIP Safety

<b>E860-0017SCEPA-60</b>	VFD 1.7A 600V 0.75KW 1HP (ND) SAFETY
<b>E860-0027SCEPA-60</b>	VFD 2.7A 600V 1.5KW 2HP (ND) SAFETY
<b>E860-0040SCEPA-60</b>	VFD 4.0A 600V 2.2KW 3HP (ND) SAFETY
<b>E860-0061SCEPA-60</b>	VFD 6.1A 600V 3.7KW 5HP (ND) SAFETY
<b>E860-0090SCEPA-60</b>	VFD 9.0A 600V 5.5KW 7.5HP (ND) SAFETY
<b>E860-0120SCEPA-60</b>	VFD 12.0A 600V 7.5KW 10HP (ND) SAFETY

### Single Port RS485

Modbus RTU- Single Port RS485

<b>E860-0017-5-60</b>	VFD 1.7A 600V 0.75KW 1HP (ND)
<b>E860-0027-5-60</b>	VFD 2.7A 600V 1.5KW 2HP (ND)
<b>E860-0040-5-60</b>	VFD 4.0A 600V 2.2KW 3HP (ND)
<b>E860-0061-5-60</b>	VFD 6.1A 600V 3.7KW 5HP (ND)
<b>E860-0090-5-60</b>	VFD 9.0A 600V 5.5KW 7.5HP (ND)
<b>E860-0120-5-60</b>	VFD 12.0A 600V 7.5KW 10HP (ND)

### Protocol Group B

CC-Link IE TSN, CC-Link IE Field Network Basic, Modbus/TCP, and PROFINET

<b>E860-0017EPB-60</b>	VFD 1.7A 600V 0.75KW 1HP (ND) ETH-PB
<b>E860-0027EPB-60</b>	VFD 2.7A 600V 1.5KW 2HP (ND) ETH-PB
<b>E860-0040EPB-60</b>	VFD 4.0A 600V 2.2KW 3HP (ND) ETH-PB
<b>E860-0061EPB-60</b>	VFD 6.1A 600V 3.7KW 5HP (ND) ETH-PB
<b>E860-0090EPB-60</b>	VFD 9.0A 600V 5.5KW 7.5HP (ND) ETH-PB
<b>E860-0120EPB-60</b>	VFD 12.0A 600V 7.5KW 10HP (ND) ETH-PB

### Protocol Group B- Safety SiI3

PROFIsafe

<b>E860-0017SCEPB-60</b>	VFD 1.7A 600V 0.75KW 1HP (ND) SAFETY
<b>E860-0027SCEPB-60</b>	VFD 2.7A 600V 1.5KW 2HP (ND) SAFETY
<b>E860-0040SCEPB-60</b>	VFD 4.0A 600V 2.2KW 3HP (ND) SAFETY
<b>E860-0061SCEPB-60</b>	VFD 6.1A 600V 3.7KW 5HP (ND) SAFETY
<b>E860-0090SCEPB-60</b>	VFD 9.0A 600V 5.5KW 7.5HP (ND) SAFETY
<b>E860-0120SCEPB-60</b>	VFD 12.0A 600V 7.5KW 10HP (ND) SAFETY

### Protocol Group C

EtherCAT

<b>E860-0017EPC-60</b>	VFD 1.7A 600V 0.75KW 1HP (ND) ETH-PC
<b>E860-0027EPC-60</b>	VFD 2.7A 600V 1.5KW 2HP (ND) ETH-PC
<b>E860-0040EPC-60</b>	VFD 4.0A 600V 2.2KW 3HP (ND) ETH-PC
<b>E860-0061EPC-60</b>	VFD 6.1A 600V 3.7KW 5HP (ND) ETH-PC
<b>E860-0090EPC-60</b>	VFD 9.0A 600V 5.5KW 7.5HP (ND) ETH-PC
<b>E860-0120EPC-60</b>	VFD 12.0A 600V 7.5KW 10HP (ND) ETH-PC

# Specifications

## Three-Phase 200V Power Supply

Model FR-E820-__		0008	0015	0030	0050	0080	0110	0175	0240	0330	0470	0600	0760	0900		
		0.1K	0.2K	0.4K	0.75K	1.5K	2.2K	3.7K	5.5K	7.5K	11K	15K	18.5K	22K		
Stocked Item		S	S	S	S	S	S	S	S	S	S	S	S	S		
Applicable Motor Capacity (kW) (*1)		LD	0.2	0.4	0.75	1.1	2.2	3.0	5.5	7.5	11	15.0	18.5	22.0	30.0	
		ND	0.1	0.2	0.4	0.75	1.5	2.2	3.7	5.5	7.5	11.0	15.0	18.5	22.0	
Output	Rated Capacity (kVA) (*2)	LD	0.5	0.8	1.4	2.4	3.8	4.8	7.8	12.0	15.9	22.3	27.5	35.1	45.8	
		ND	0.3	0.6	1.2	2.0	3.2	4.4	7.0	9.6	13.1	18.7	23.9	30.3	35.9	
	Rated Current (A) (*7)	LD	1.3 (1.1)	2 (1.7)	3.5 (3.0)	6.0 (5.1)	9.6 (8.2)	12 (10.2)	19.6 (16.7)	30 (25.5)	40 (34)	56.0 (47.6)	69.0 (58.7)	88.0 (74.8)	115.0 (97.8)	
		ND	0.8 (0.8)	1.5 (1.4)	3 (2.5)	5 (4.1)	8 (7)	11 (10)	17.5 (16.5)	24 (23)	33 (31)	47.0 (44.0)	60.0 (57.0)	76.0 (72.0)	90.0 (86.0)	
Overload Current Rating (*3)		LD	120% 60 s, 150% 3 s (inverse-time characteristics) at surrounding air temperature of 50°C													
		ND	150% 60 s, 200% 3 s (inverse-time characteristics) at surrounding air temperature of 50°C													
Voltage (*4)		Three-phase 200 to 240V														
Regenerative Braking	Brake Transistor Max. Brake Torque (ND Reference) (*5)			Built-in												
		150%		100%		50%		20%								
Rated Input AC (DC) Voltage/Frequency		Three-phase 200 to 240V 50/60 Hz (283 to 339 VDC) (*9)														
Permissible AC (DC) Voltage Fluctuation		170 to 264V 50/60 Hz (240 to 373 VDC) (*9)														
Permissible Frequency Fluctuation		±5%														
Power Supply	Rated Input Current (A) (*8)	Without DC Reactor	LD	1.9	3.0	5.1	8.2	12.5	16.1	25.5	37.1	48.6	74.3	90.5	112.9	139.5
			ND	1.4	2.3	4.5	7.0	10.7	15.0	23.1	30.5	41.0	63.6	79.9	99.0	114.3
		With DC Reactor	LD	1.3	2.0	3.5	6.0	9.6	12.0	20.0	30.0	40.0	56.0	69.0	88.0	115.0
			ND	0.8	1.5	3.0	5.0	8.0	11.0	17.5	24.0	33.0	47.0	60.0	76.0	90.0
	Power Supply Capacity (kVA) (*6)	Without DC Reactor	LD	0.7	1.1	1.9	3.1	4.8	6.2	9.7	15.0	19.0	29.0	35.0	43.0	54.0
			ND	0.5	0.9	1.7	2.7	4.1	5.7	8.8	12.0	16.0	25.0	31.0	38.0	44.0
		With DC Reactor	LD	0.5	0.8	1.3	2.3	3.7	4.6	7.5	11.0	15.0	21.0	26.0	34.0	44.0
			ND	0.3	0.6	1.1	1.9	3.0	4.2	6.7	9.1	13.0	18.0	23.0	29.0	34.0
Protective Structure (IEC 60529)		Open type (IP20)														
Cooling System		Natural						Forced air								
Approx. Weight (kg) (*8)		0.5	0.5	0.7	1.0	1.4	1.4	1.8	3.3	3.3	5.4	5.6	11.0	11.0		

Notes: For detailed information please reference product manual.

## Three-Phase 400V Class

Model FR-E840-__		0016	0026	0040	0060	0095	0120	0170	0230	0300	0380	0440		
		0.4K	0.75K	1.5K	2.2K	3.7K	5.5K	7.5K	11K	15K	18.5K	22K		
Stocked Item		S	S	S	S	S	S	S	S	S	S	S		
Applicable Motor Capacity (kW) (*1)		0.75	1.5	2.2	3.0	5.5	7.5	11.0	15.0	18.5	22.0	30.0		
		0.4	0.75	1.5	2.2	3.7	5.5	7.5	11.0	15.0	18.5	22.0		
Output	Rated Capacity (kVA) (*2)			1.6	2.7	4.2	5.3	8.5	13.3	17.5	26.7	31.2	34.3	45.7
				1.2	2.0	3.0	4.6	7.2	9.1	13.0	17.5	22.9	29.0	33.5
	Rated Current (A) (*7)			2.1 (1.8)	3.5 (3.0)	5.5 (4.7)	6.9 (5.9)	11.1 (9.4)	17.5 (14.9)	23.0 (19.6)	35.0 (29.8)	41.0 (34.9)	45.0 (38.3)	60.0 (51.0)
				1.6 (1.4)	2.6 (2.2)	4.0 (3.8)	6.0 (5.4)	9.5 (8.7)	12.0	17.0	23.0	30.0	38.0	44.0
Overload Current Rating (*3)		120% 60 s, 150% 3 s (inverse-time characteristics) at surrounding air temperature of 50°C												
		150% 60 s, 200% 3 s (inverse-time characteristics) at surrounding air temperature of 50°C												
Rated Voltage (*4)		Three-phase 380 to 480V												
Regenerative Braking	Brake Transistor Max. Brake Torque (ND Reference) (*5)			Built-in										
		100%		50%		20%								
Rated Input AC (DC) Voltage/Frequency		Three-phase 380 to 480 V 50 Hz / 60 Hz (*9)												
Permissible AC (DC) Voltage Fluctuation		323 to 528 V 50/60 Hz (457 to 740 VDC) (*9)												
Permissible Frequency Fluctuation		±5%												
Power Supply	Rated Input Current (A) (*8)	Without DC Reactor	LD	3.3	6.0	8.9	10.7	16.2	24.9	32.4	46.7	54.2	59.1	75.6
			ND	2.7	4.4	6.7	9.5	14.1	17.8	24.7	32.1	41.0	50.8	57.3
		With DC Reactor	LD	2.1	3.5	5.5	6.9	11.0	18.0	23.0	35.0	41.0	45.0	60.0
			ND	1.6	2.6	4.0	6.0	9.5	12.0	17.0	23.0	30.0	38.0	44.0
	Power Supply Capacity (kVA) (*6)	Without DC Reactor	LD	2.5	4.5	6.8	8.2	12.4	19.0	25.0	36.0	42.0	45.0	58.0
			ND	2.1	3.4	5.1	7.2	10.8	14.0	19.0	25.0	32.0	39.0	44.0
		With DC Reactor	LD	1.6	2.7	4.2	5.3	8.5	13.0	18.0	27.0	31.0	34.0	46.0
			ND	1.2	2.0	3.0	4.6	7.2	9.1	13.0	18.0	23.0	29.0	34.0
Protective Structure (IEC 60529)		Open type (IP20)												
Cooling System		Natural					Forced air							
Approx. Weight (kg) (*8)		1.2	1.2	1.4	1.8	1.8	2.4	2.4	4.8	4.9	11.0	11.0		

Notes: For detailed information please reference product manual.

## Three-Phase 575V Class

Model FR-E860-__			0017	0027	0040	0061	00900	0120	
			0.75K	1.5k	2.2K	3.7K	5.5K	7.5K	
Stocked Item			S	S	S	S	S	S	
Applicable Motor Capacity (kW) (*1)			LD 1.5	2.2	3.7	5.5	7.5	11	
			ND 0.75	1.5	2.2	3.7	5.5	7.5	
Output	Rated Capacity (kVA) (*2)		LD 2.5	3.6	5.6	8.2	11.0	15.9	
			ND 1.7	2.7	4.0	6.1	9.0	12.0	
	Rated Current (A) (*7)		LD 2.5 (2.1)	3.6 (3.0)	5.6 (4.8)	8.2 (7.0)	11 (9.0)	16 (13.6)	
			ND 1.7	2.7	4	6.1	9	12	
	Overload Current Rating (*3)		LD	120% 60 s, 150% 3 s (inverse-time characteristics) at surrounding air temperature of 50°C					
			ND	150% 60 s, 200% 3 s (inverse-time characteristics) at surrounding air temperature of 50°C					
Rated Voltage (*4)			Three-phase 525 to 600 V						
Regenerative Braking	Brake Transistor		Built-in						
	Maximum Brake Torque (ND Reference) (*5)		100%	50%	20%				
Rated Input AC Voltage/Frequency			Three-phase 575V 50 60 Hz						
Permissible AC Voltage Fluctuation			490 to 632V 60 Hz						
Permissible Frequency Fluctuation			±5%						
Power Supply	Rated Input Current (A) (*8)	Without DC Reactor	LD 4.3	5.9	8.9	12.4	15.9	22.4	
		With DC Reactor	ND 3.0	4.6	6.6	9.5	13.3	17.4	
		Without DC Reactor	LD 2.5	3.6	5.6	8.2	11.0	16.0	
		With DC Reactor	ND 1.7	2.7	4.0	6.1	9.0	12.0	
	Power Supply Capacity (kVA) (*6)	Without DC Reactor	LD 4.3	5.9	8.9	12.3	16.0	23.0	
		With DC Reactor	ND 3.0	4.6	6.6	9.5	14.0	18.0	
		Without DC Reactor	LD 2.5	3.6	5.6	8.2	11.0	16.0	
		With DC Reactor	ND 1.7	2.7	4.0	6.1	9.0	12.0	
Protective Structure (IEC 60529)			Enclosed type (IP20)						
Cooling System			Natural				Forced air		
Approx. Weight (kg) (*8)			1.9	1.9	1.9	2.4	2.4	2.4	

Notes: For detailed information please reference product manual.

## Single-Phase 200V Class

Model E820S-__			0008	0015	0030	0050	0080	011	
			0.1K	0.2K	0.4K	0.75K	1.5K	2.2K	
Stocked Item			S	S	S	S	S	S	
Applicable Motor Capacity (kW) (*1)			ND 0.1	0.2	0.4	0.75	1.5	2.2	
Rated Capacity (kVA) (*2)			ND 0.3	0.6	1.2	2.0	3.2	4.4	
Rated Current (A) (*7)			ND 0.8 (0.8)	1.5 (1.4)	3.0 (2.5)	5.0 (4.1)	8.0 (7.0)	11.0 (10.0)	
Overload Current Rating (*3)			ND	150% 60 s, 200% 3 s (inverse-time characteristics) at surrounding air temperature of 50°C					
Rated Voltage (*4)			Three-phase 200 to 240 V						
Regenerative Braking	Brake Transistor		Not installed			Built-in			
	Maximum Brake Torque (ND Reference) (*5)		150%	100%	50%	20%			
Rated Input AC Voltage/Frequency			Single-phase 200 to 240 V 50/60 Hz						
Permissible AC Voltage Fluctuation			170 to 264 V, 50/60 Hz						
Permissible Frequency Fluctuation			±5%						
Power Supply	Rated Input Current (A) (*8)	Without DC Reactor	ND 2.3	4.1	7.9	11.2	17.9	25.0	
		With DC Reactor	1.4	2.6	5.2	8.7	13.9	19.1	
	Power Supply Capacity (kVA) (*6)	Without DC Reactor	ND 0.5	0.9	1.7	2.5	3.9	5.5	
		With DC Reactor	0.3	0.6	1.1	1.9	3.0	4.2	
Protective Structure (IEC 60529)			Open type (IP20)						
Cooling System			Natural				Forced air		
Approx. Weight (kg)			0.5	0.5	0.8	1.3	1.4	1.9	

### Notes:

- The motor capacity indicates the maximum capacity of a 4-pole standard motor driven by all of the inverters in parallel connection.
- The rated output capacity indicated assumes that the output voltage is 575 V.
- The % value of the overload current rating indicated is the ratio of the overload current to the inverter's rated output current. For repeated duty, allow time for the inverter and motor to return to or below the temperatures under 100% load.
- The maximum output voltage does not exceed the power supply voltage. The maximum output voltage can be changed within the setting range. However, the pulse voltage value of the inverter output side voltage remains unchanged at about  $\sqrt{2}$  that of the power supply.
- The amount of braking torque is the average short-term torque (which varies depending on motor loss) that is generated when a motor decelerates in the shortest time by itself from 60 Hz. It is not continuous regenerative torque. The average deceleration torque becomes lower when a motor decelerates from a frequency higher than the base frequency. The inverter is not equipped with a built-in brake resistor. Use a brake resistor for an operation with large regenerative power. A brake unit can be also used.
- The power supply capacity varies with the value of the power supply side inverter impedance (including those of the input reactor and cables).
- Setting 2 kHz or more in Pr. 72 PWM frequency selection to perform low acoustic noise operation in the surrounding air temperature exceeding 40°C, the rated output current is the value in parenthesis.
- The rated input current indicates a value at a rated output voltage. The impedance at the power supply side (including those of the input reactor and cables) affects the rated input current.

# Common Specifications

Control Specifications	Control Method		Soft-PWM control/high carrier frequency PWM control	
		Induction Motor	Selectable among V/F control, Advanced magnetic flux vector control, and Real sensorless vector control	
		PM Motor	PM sensorless vector control	
	Output Frequency Range	Induction Motor	0.2 to 590 Hz (The upper-limit frequency is 400 Hz under Advanced magnetic flux vector control and Real sensorless vector control.)	
		PM Motor	0.2 to 400 Hz (not operable at maximum motor frequency or higher)	
	Frequency Setting Resolution	Analog Input	0.015 Hz /60 Hz at 0 to 10V / 12 bits (terminals 2 and 4) 0.03 Hz /60 Hz at 0 to 5V / 11 bits or 0 to 20 mA / 11 bits (terminals 2 and 4)	
		Digital Input	0.01 Hz	
	Frequency Accuracy	Analog Input	Within ±0.2% of the max. output frequency (25°C ± 10°C)	
		Digital Input	Within 0.01% of the set output frequency	
	Voltage/Frequency Characteristics			Base frequency can be set from 0 to 590 Hz. Constant-torque/variable torque pattern can be selected. (Available with induction motors only)
	Starting Torque	Induction Motor	150% 0.5 Hz (Advanced magnetic flux vector control) 200% 0.3 Hz (0.4K to 3.7K), 150% 0.3 Hz (5.5K or more) (Real sensorless vector control)	
		PM Motor	50%	
	Torque Boost			Manual torque boost (available with induction motors only)
	Acceleration/Deceleration Time Setting			0 to 3600 s (acceleration and deceleration can be set individually), linear or S-pattern acceleration/deceleration mode
DC Injection Brake	Induction Motor	Operation frequency (0 to 120 Hz), operation time (0 to 10 s), operation voltage (0 to 30%) can be changed.		
	PM Motor	Operation time (0 to 10 s) can be changed, operation voltage (operating current) is fixed.		
Stall Prevention Operation Level			Operation current level can be set (0 to 220% adjustable), whether to use the function or not can be selected.	
Torque Limit Level			Torque limit value can be set (0 to 400% variable)	
Operation Specifications	Frequency Setting Signal	Analog Input	Terminals 2 and 4: 0 to 10V, 0 to 5V, 4 to 20 mA (0 to 20 mA) are available.	
		Digital Input	Input using the operation panel. Four-digit BCD or 15-bit binary (when used with option FR-A8AX E kit)	
	Start Signal			Forward and reverse rotation or start signal automatic self-holding input (3-wire input) can be selected.
	Input Signal (Standard Model: 7, Ethernet Model: 2)			Low-speed operation command, Middle-speed operation command, High-speed operation command, Output stop, Forward rotation command, Reverse rotation command, Inverter reset The input signal can be changed using Pr.178 to Pr.189 (input terminal function section).
	Operational Functions			Maximum and minimum frequency settings, multi-speed operation, acceleration/deceleration pattern, thermal protection, DC injection brake, starting frequency, JOG operation, output stop (MR3), stall prevention, regeneration avoidance, frequency jump, rotation display, automatic restart after instantaneous power failure, remote setting, automatic acceleration/deceleration, retry function, carrier frequency selection, fast-response current limit, forward/reverse rotation prevention, operation mode selection, slip compensation, droop control, speed smoothing control, traverse, auto tuning, applied motor selection, R3-485 communication (*1), Ethernet communication (*2), PID control, easy dancer control, cooling fan operation selection, stop selection (deceleration stop/coasting), power-failure deceleration stop function, stop-on-contact control, Plc function, life diagnosis, maintenance timer, current average monitor, multiple rating, speed control, torque control, torque limit, safety stop function
	Output Signal	Open Collector Output (Standard Model: 2) Relay Output 1	Inverter running, Up to frequency, Fault The output signal can be changed using Pr.190 to Pr.196 (output terminal function selection)	
		Analog Output (AM Type)	-10 to +10 V /12 bits	
	Protective/Warning Function	Protective Functions		
		Warning Functions		
	Environment	Surrounding Air Temperature		
Ambient Humidity				
Storage Temperature (*4)				
Atmosphere				
Altitude/Vibration (*5)				

**Notes:**

1. Enabled only for standard models.
2. Enabled only for Ethernet models.
3. This protective function is not available in the initial status.
4. Temperature applicable for a short time, e.g. in transit.
5. For the installation at an altitude above 1000m, consider a 3% reduction in the rated current per 500m increase in altitude.

# Terminal Connection Diagram FR-E800

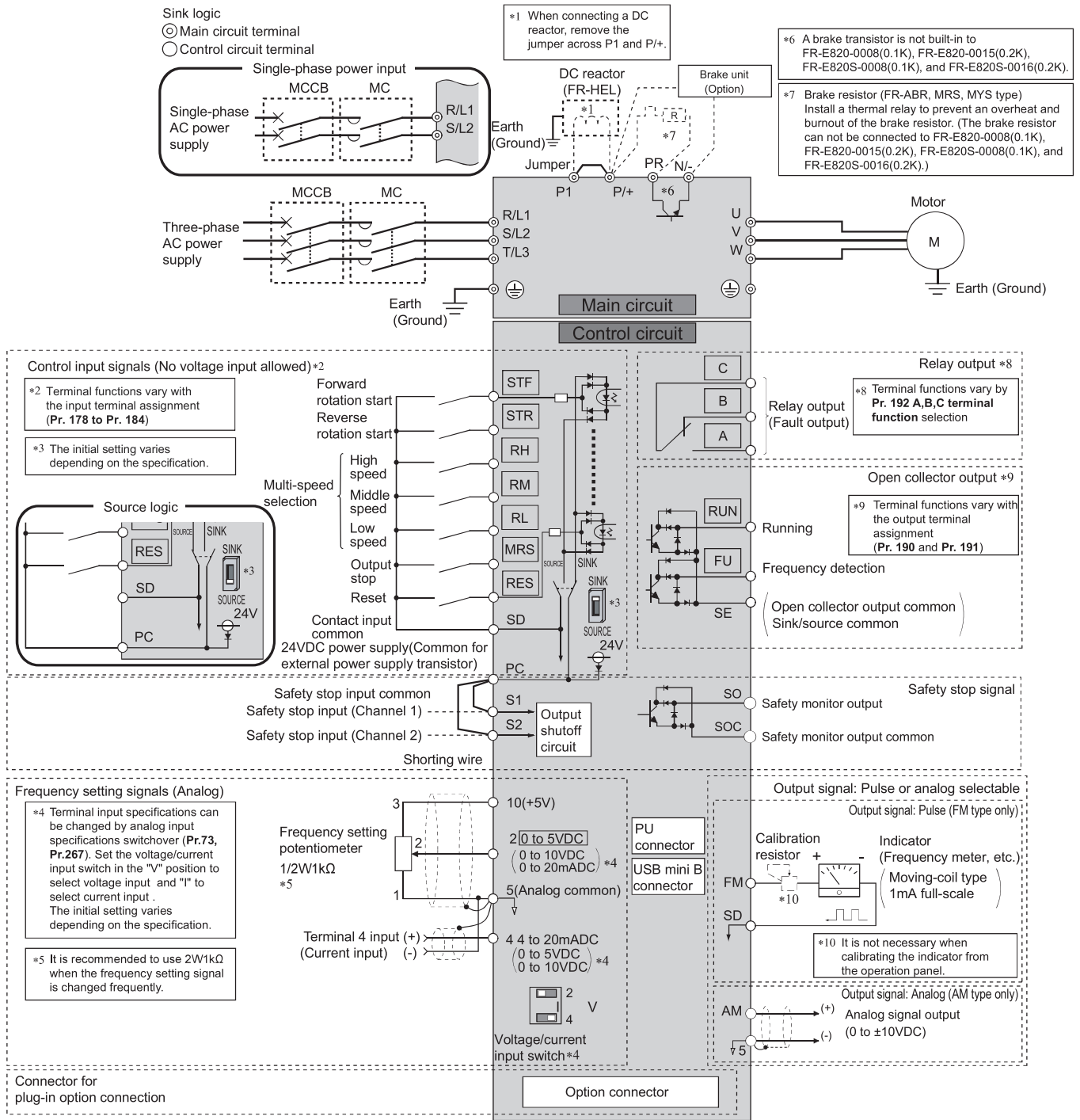



## Terminal Specifications FR-E800

Type	Terminal Symbol	Terminal Name	Description			
Main Circuit	R/L1, S/L2, T/L3 (*1)	AC Power Input	Connect to the commercial power supply. Do not connect anything to these terminals when using the high power factor converter (FR-HC2) or the multifunction regeneration converter (FR-XC) in common bus regeneration mode.			
	U, V, W	Inverter Output	Connect a three-phase squirrel-cage motor or PM motor.			
	P/+, PR	Brake Resistor Connection	Connect a brake transistor (MRS type, MYS type, FR-ABR) across terminals P/+ -PR. (The brake resistor cannot be connected to the 0.1K or 0.2K)			
	P/+, N/-	Brake Unit Connection	Connect the brake unit (FR-BU2), multifunction regeneration converter (FR-XC), or high power factor converter (FR-HC2).			
	P/+, P1	DC Reactor Connection	Remove the jumper across terminals P/+ -P1 and connect a DC reactor. When a DC reactor is not connected, the jumper across terminals P/+ and P1 should not be removed.			
		Earth (Ground)	For earthing (grounding) the inverter chassis. Must be earthed (grounded).			
Input Signal	Contact Input	STF (*2)	Forward Rotation Start	When the STF and STR signals are turned on simultaneously, the stop command is given.	Input resistance: 4.7Ω, voltage when contacts are open: 21 to 26 VDC, current when contacts are short-circuited: 4 to 6 mADC	
		STR (*2)	Reverse Rotation Start			
		RH, RM, RL (*2)	Multi-speed Selection	Multi-speed can be selected according to the combination of RH, RM and RL signals.		
		MRS (*2)	Output Stop	Turn on the MRS signal (20ms or more) to stop the inverter output. Use to shut off the inverter output when stopping the motor by electromagnetic brake.		
		RES (*2)	Reset	Use to reset alarm output provided when protective circuit is activated. Turn on the RES signal for more than 0.1s, then turn it off. It is possible to set the initial setting to "always enabled". By setting Pr. 75, reset can be set enabled only at fault occurrence. Recover about 1s after reset is canceled.		
	Frequency Setting	10	Frequency Setting Power Supply	Used as power supply when connecting potentiometer for frequency setting (speed setting) from outside of the inverter.	5 VDC ± 0.5 V permissible load current 10 mA	
		2	Frequency Setting (Voltage)	Inputting 0 to 5 VDC (or 0 to 10 VDC) provides the maximum output frequency at 5 V (or 10 V) and makes input and output proportional. Use Pr.73 to switch between input 0 to 5 VDC (initial setting) and 0 to 10 VDC input. Set the voltage/current input switch to the "I" position to select current input (0 to 20 mA).	Voltage input: Input resistance 10 kΩ ± 1 kΩ Permissible maximum voltage 20 VDC	
		4	Frequency Setting (Current)	Inputting 4 to 20 mADC (or 0 to 5 VDC, 0 to 10 VDC) provides the maximum output frequency at 20 mA and makes input and output proportional. This input signal is valid only when the AU signal is ON (terminal 2 input is invalid). To use the terminal 4 (current input at initial setting), assign "4" to any parameter from Pr.178 to Pr.184 (Input terminal function selection) before turning ON the AU signal. Use Pr.267 to switch among input 4 to 20 mA (initial setting), 0 to 5 VDC, and 0 to 10 VDC. Set the voltage/current input switch in the "V" position to select voltage input (0 to 5 V / 0 to 10 V).	Current input: Input resistance 245Ω ± 5Ω Maximum permissible current 30 mA.	
	Output Signal	Relay	A, B, C	Relay Output (Fault Output)	1 changeover contact output indicates that the inverter fault occurs. Fault: discontinuity across B-C (continuity across A-C), Normal: continuity across B-C (discontinuity across A-C)	Contact capacity 240 VAC 2A (power factor = 0.4) 30 VDC 1A
		Open Collector	RUN	Inverter Running	The output is in LOW state when the inverter output frequency is equal to or higher than the starting frequency (initial value: 0.5 Hz). The output is in HIGH state during stop or DC injection brake operation. (*3)	Permissible load 24 VDC (Maximum 27 VDC) 0.1 A (a voltage drop is 3.4 V maximum when the signal is on)
FU			Frequency Detection	The output is in LOW state when the inverter output frequency is equal to or higher than the preset detection frequency, and is in HIGH state when it is less than the preset detection frequency. (*3)		
Pulse		FM (*4)	For Meter	Select one e.g. output frequency from monitor items. (Not output during inverter reset.) The output signal is proportional to the magnitude of the corresponding monitoring item	Output item: output frequency (initial setting)	Permissible load current 1 mA 1440 pulses/s at 60 Hz
Analog	AM (*4)	Analog Voltage Output	Output signal 0 to 0 VDC, permissible load current 1 mA (load impedance 10 kΩ or more), resolution: 12 bits			
Safety Stop Signal	S1	Safety Stop Input (Channel 1)	Terminals S1 and S2 are used for the safety stop input signal for the safety relay module. Terminals S1 and S2 are used at the same time (dual channel). Inverter output is shutoff by shortening/opening between terminals S1 and SIC, or between S2 and SIC. In the initial status, terminals S1 and S2 are shorted with terminal PC by shorting wires. Terminal SIC is shorted with terminal SD. Remove the shorting wires and connect the safety relay module when using the safety stop function.	Input resistance 4.7 kΩ Voltage when contacts are open 21 to 26 VDC Current when contacts are short-circuited 4 to 6 mADC		
	S2	Safety Stop Input (With 24 VDC Input) (Channel 2)				
	SO	Safety Monitor Output (Open Collector Output)	Indicates the safety stop input signal status. Switched to LOW when the status is other than the internal safety circuit failure. Refer to the FR-E800 Instruction Manual (Functional Safety) (BCN-A23488-000) when the signal is switched to HIGH while both terminals S1 and S2 are open. (Please contact your sales representative for the manual.)		Permissible load 24 VDC (max. 27 VDC) 0.1 A (The voltage drop is 3.4 V at maximum while the signal is ON.)	

Continued next page

## Terminal Specifications FR-E800 (CONTINUED)

Common Terminal	SD	Contact Input Common (Sink) (Initial Setting)	Common terminal for contact input terminal (sink logic) and terminal FM.	
		External Transistor Common (Source)	Connect this terminal to the power supply common terminal of a transistor output (open collector output) device, such as a programmable controller, in the source logic to avoid malfunction by undesirable currents.	
		24VDC Power Supply Common	Common output terminal for 24VDC 0.1A power supply (PC terminal). Isolated from terminals 5 and SE.	
	PC	External Transistor Common (Sink) (Negative Common)	Connect this terminal to the power supply common terminal of a transistor output (open collector output) device, such as a programmable controller, in the sink logic to avoid malfunction by undesirable currents.	Power supply voltage range: 22.5 to 27 VDC, permissible load current: 100 mA
		Safety Stop Input Terminal Common	Common terminal for safety stop input terminals.	
		Contact Input Common (Source) (Positive Common)	Common terminal for contact input terminal (source logic).	
		24VDC Power Supply	Can be used as 24 VDC 0.1 A power supply.	
	5	Frequency Setting Common	Common terminal for the frequency setting signals (terminals 2 or 4). Do not earth (ground).	
	SE	Open Collector Output Common	Common terminal of terminal RUN and FU.	
	SOC	Safety Monitor Output Terminal Common	Common terminal for terminal SO.	
Communication	–	PU Connector	With the PU connector, RS-485 communication can be made. Conforming standard: EIA-485 (RS-485) Transmission format: Multi-drop link Communication speed: 300 to 115200bps Overall extension: 500m	
	–	USB Connector (*5)	USB connection with a personal computer can be established. Setting, monitoring and testing of the inverter can be performed using FR Configurator2. Interface: conforms to USB 1.1 Transmission Speed: 12 Mbps Connector: USB mini B connector (receptacle mini B type)	

### Notes:

- Terminal T/L3 is not available for the single-phase power input models.
- Terminal functions can be selected using Pr.178 to Pr.184 (Input terminal function selection).
- An open collector transistor is ON (conductive) in LOW state. The transistor is OFF (not conductive) in HIGH state.
- Terminal FM is provided for the FM type inverter. Terminal AM is provided for the AM type inverter.
- USB bus power connection is available. The maximum SCCR is 500 mA. A PU connector cannot be used during USB bus power connection.

Terminal Connection Specifications FR-E800-E

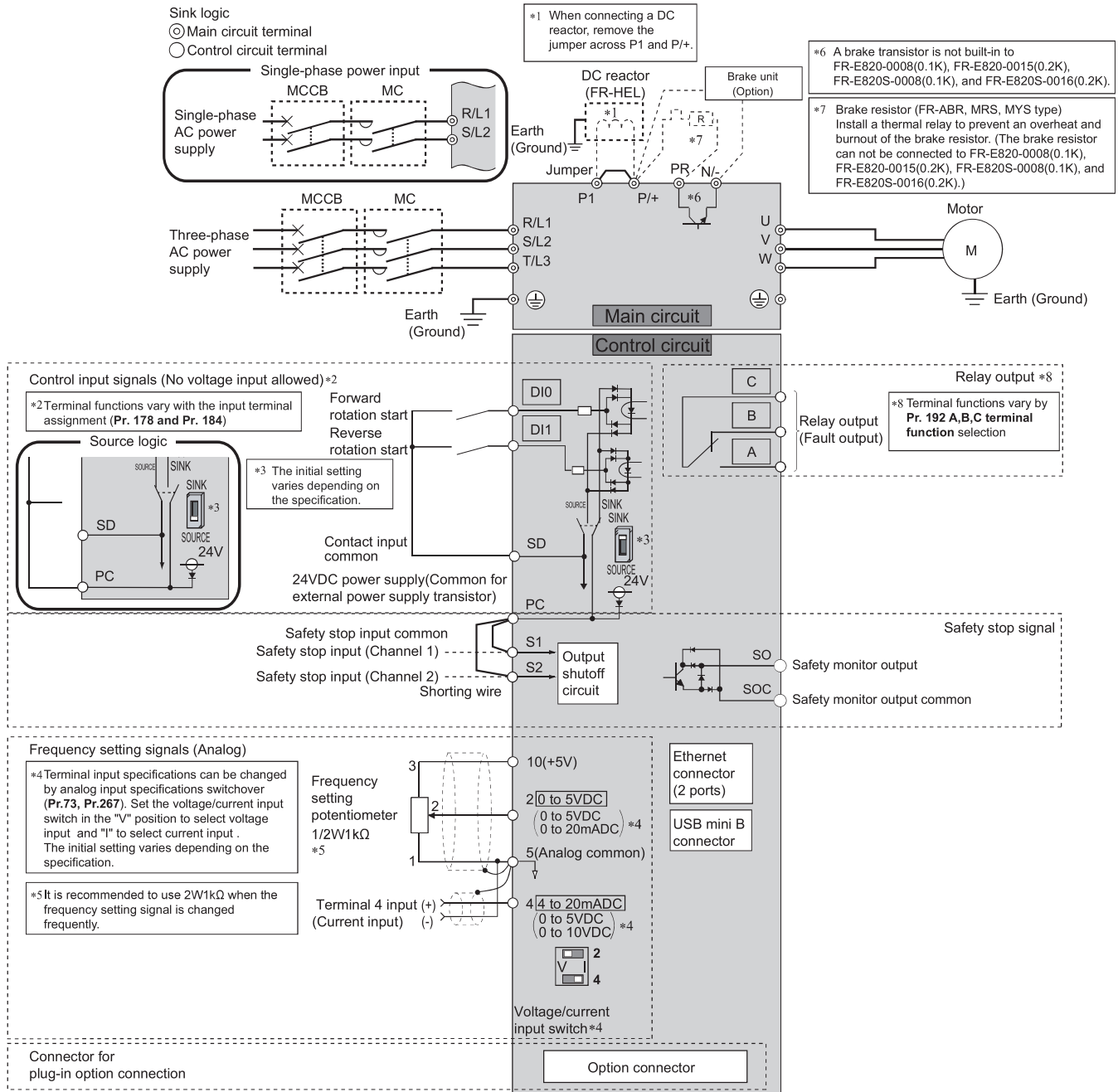

## Terminal Specifications FR-E800-E

Type	Terminal Symbol	Terminal Name	Description			
Main Circuit	R/L1, S/L2, T/L3	AC Power Input	Connect to the commercial power supply. Do not connect anything to these terminals when using the high power factor converter (FR-HC2) or the multifunction regeneration converter (FR-XC) in common bus regeneration mode.			
	U, V, W	Inverter Output	Connect a three-phase squirrel-cage motor or PM motor.			
	P/+, PR	Brake Resistor Connection	Connect a brake transistor (MRS type, MYS type, FR-ABR) across terminals P/+-PR. (The brake resistor cannot be connected to the 0.1K or 0.2K)			
	P/+, N/-	Brake Unit Connection	Connect the brake unit (FR-BU2), multifunction regeneration converter (FR-XC), or high power factor converter (FR-HC2).			
	P/+, P1	DC Reactor Connection	Remove the jumper across terminals P/+-P1 and connect a DC reactor. When a DC reactor is not connected, the jumper across terminals P/+ and P1 should not be removed.			
	⊕	Earth (Ground)	For earthing (grounding) the inverter chassis. Must be earthed (grounded).			
Input Signal	Contact Input	DIO (*2)	Forward Rotation Start	When the DIO and DI1 signals are turned on simultaneously, the stop command is given.	Input resistance: 4.7Ω, voltage when contacts are open: 21 to 26 VDC, current when contacts are short-circuited: 4 to 6 mADC	
		DI1 (*2)	Reverse Rotation Start			
	Frequency Setting	10	Frequency Setting Power Supply	Used as power supply when connecting potentiometer for frequency setting (speed setting) from outside of the inverter.		5 VDC ± 0.5 V permissible load current 10 mA
		2	Frequency Setting (Voltage)	Inputting 0 to 5 VDC (or 0 to 10 VDC) provides the maximum output frequency at 5 V (or 10 V) and makes input and output proportional. Use Pr.73 to switch between input 0 to 5 VDC (initial setting) and 0 to 10 VDC input. Set the voltage/current input switch to the "I" position to select current input (0 to 20 mA).		Voltage input: Input resistance 10 kΩ ± 1 kΩ Permissible maximum voltage 20 VDC  Current input: Input resistance 245Ω ± 5Ω Maximum permissible current 30 mA.
		4	Frequency Setting (Current)	Inputting 4 to 20 mADC (or 0 to 5 VDC, 0 to 10 VDC) provides the maximum output frequency at 20 mA and makes input and output proportional. This input signal is valid only when the AU signal is ON (terminal 2 input is invalid). To use the terminal 4 (current input at initial setting), assign "4" to any parameter from Pr.178 to Pr.184 (Input terminal function selection) before turning ON the AU signal. Use Pr.267 to switch among input 4 to 20 mA (initial setting), 0 to 5 VDC, and 0 to 10 VDC. Set the voltage/current input switch in the "V" position to select voltage input (0 to 5 V / 0 to 10 V).		
	Output Signal	Relay	A, B, C	Relay Output (Fault Output)	1 changeover contact output indicates that the inverter fault occurs. Fault: discontinuity across B-C (continuity across A-C). Normal: continuity across B-C (discontinuity across A-C)	
Safety Stop Signal	S1	Safety Stop Input (Channel 1)	Terminals S1 and S2 are used for the safety stop input signal for the safety relay module. Terminals S1 and S2 are used at the same time (dual channel). Inverter output is shutoff by shortening/opening between terminals S1 and SIC, or between S2 and SIC. In the initial status, terminals S1 and S2 are shorted with terminal PC by shorting wires. Terminal SIC is shorted with terminal SD. Remove the shorting wires and connect the safety relay module when using the safety stop function.		Input resistance 4.7 kΩ Voltage when contacts are open 21 to 26 VDC Current when contacts are short-circuited 4 to 6 mADC	
	S2	Safety Stop Input (With 24 VDC Input) (Channel 2)				
	SO	Safety Monitor Output (Open Collector Output)	Indicates the safety stop input signal status. Switched to LOW when the status is other than the internal safety circuit failure. Switched to HIGH during the internal safety circuit failure status. (LOW is when the open collector output transistor is ON (conducted). HIGH is when the transistor is OFF (not conducted).) Refer to the FRE800 Instruction Manual (Functional Safety) (BCN-A23488-000) when the signal is switched to HIGH while both terminals S1 and S2 are open. (Please contact your sales representative for the manual.)		Permissible load 24 VDC (maximum 27 VDC) 0.1 A (The voltage drop is 3.4 V at maximum while the signal is ON.)	
Common Terminal	SD	Contact Input Common (sink) (Negative Common)	Common terminal for contact input terminal (sink logic).			
		External Transistor Common (Source) (Positive Common)	Connect this terminal to the power supply common terminal of a transistor output (open collector output) device, such as a programmable controller, in the source logic to avoid malfunction by undesirable current.			
		24 VDC Power Supply Common	Common output terminal for 24VDC 0.1A power supply (PC terminal). Isolated from terminals 5 and SE.			
	PC	External Transistor Common (Sink) (Negative Common)	Connect this terminal to the power supply common terminal of a transistor output (open collector output) device, such as a programmable controller, in the sink logic to avoid malfunction by undesirable currents.		Power supply voltage range: 22.5 to 26.5 VDC, permissible load current: 100 mA	
		Safety Stop Input Terminal Common	Common terminal for safety stop input terminals.			
		Contact Input Common (Source) (Positive Common)	Common terminal for contact input terminal (source logic).			
		24 VDC Power Supply	Can be used as 24 VDC 0.1 A power supply.			
5	Frequency Setting Common	Common terminal for the frequency setting signals (terminals 2 or 4). Do not earth (ground).				
SOC	Safety Monitor Output Terminal Common	Common terminal for terminal SO.				
Communication	-	Ethernet Connector (2-Port) (*3)	Communication can be made via Ethernet. Category: 100BASE-TX/10BASE-T • Data transmission speed: 100 Mbps (100BASE-TX) / 10 Mbps (10BASE-T) • Transmission method: Baseband • Maximum segment length: 100m between the hub and the inverter • Number of cascade connection stages: Up to 2 (100BASE-TX) / up to 4 (10BASE-T) • Interface: RJ-45 Number of interfaces available: 2 • IP version: IPv4			
	-	USB Connector (*4)	USB connection with a personal computer can be established. Setting, monitoring and testing of the inverter can be performed using FR Configurator2: Interface: conforms to USB 1.1 • Transmission Speed: 12 Mbps • Connector: USB mini B connector (receptacle mini B type)			

### Notes:

- Terminal T/L3 is not available for the single-phase power input models.
- Terminal functions can be selected using Pr.178, Pr.179 (Input terminal function selection).
- Do not connect the parameter unit. The inverter may be damaged.
- USB bus power connection is available. The maximum SCCR should be 500 mA.

## Terminal Connection Specifications FR-E800-SCE

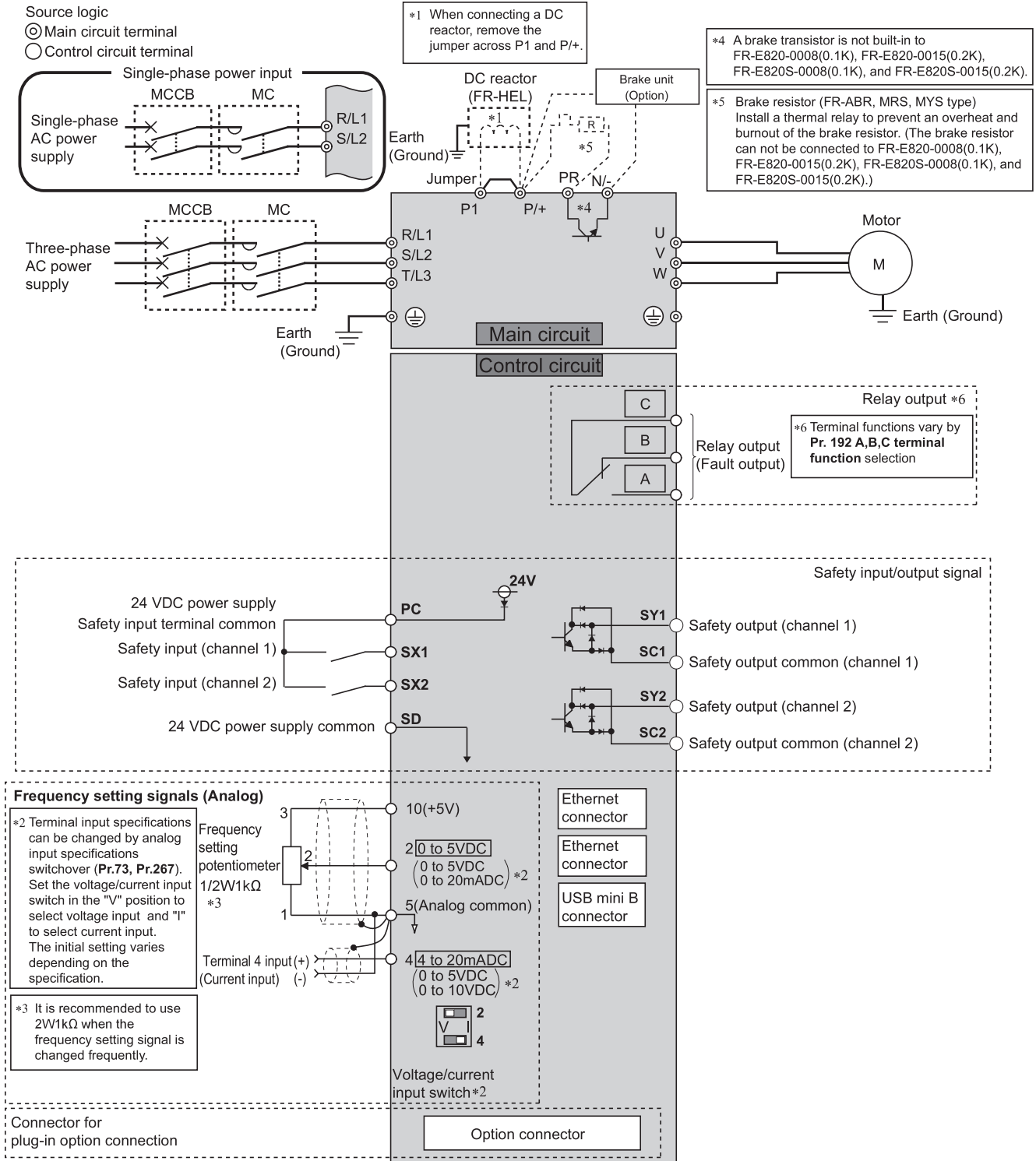

## Terminal Specifications FR-E800-SCE

Type	Terminal Symbol	Terminal Name	Description		
Main Circuit	R/L1, S/L2, T/L3 (*1)	AC Power Input	Connected to the commercial power supply.		
	U, V, W	Inverter Output	Connect a three-phase squirrel-cage motor or PM motor.		
	P/+, PR	Brake Resistor Connection	Connect an optional brake transistor (MRS, MYS, FR-ABR) between terminal P/+ and PR. (Not available for FR-E820-0008(0.1K), FR-E820-0015(0.2K), FR-E820S-0008(0.1K), and FR-E820S-0015(0.2K).)		
	P/+, N/-	Brake Unit Connection	Connect the brake unit (FR-BU2, FR-BU, or BU) or the multifunction regeneration converter (FR-XC in power regeneration mode) to these terminals.		
	P/+, P1	DC Reactor Connection	Remove the jumper across terminals P/+ and P1, and connect a DC reactor. When a DC reactor is not connected, the jumper across terminals P/+ and P1 should not be removed.		
		Earth (Ground)	For earthing (grounding) the inverter chassis. Be sure to earth (ground) the inverter.		
Input Signal	Frequency Setting	10	Frequency Setting Power Supply	For earthing (grounding) the inverter chassis. Be sure to earth (ground) the inverter.	5 ±0.5 VDC, Permissible load current: 10 mA
		2	Frequency Setting (Voltage)	Inputting 0 to 5 VDC (or 0 to 10 VDC) provides the maximum output frequency at 5 V (or 10 V) and makes input and output proportional. Use Pr.73 to switch among input 0 to 5 VDC (initial setting), 0 to 10 VDC, and 0 to 20 mA. * The initial setting varies depending on the specification. Set the voltage/current input switch to the "I" position to select current input (0 to 20 mA).	For voltage input, Input resistance: 10 ±1 kΩ Maximum permissible voltage: 20 VDC For current input, Input resistance: 245 ±5 Ω Permissible maximum current: 30 mA
		4	Frequency Setting (Current)	Inputting 4 to 20 mADC (or 0 to 5 VDC, 0 to 10 VDC) provides the maximum output frequency at 20 mA and makes input and output proportional. This input signal is valid only when the AU signal is ON (terminal 2 input is invalid). To use terminal 4 (current input at initial setting), assign "4" to Pr.178 or Pr.189 (Input terminal function selection) before turning ON the AU signal. * The initial setting varies depending on the specification. Use Pr.267 to switch among input 4 to 20 mA (initial setting), 0 to 5 VDC, and 0 to 10 VDC. Set the voltage/current input switch in the "V" position to select voltage input (0 to 5 V / 0 to 10 V).	
Output Signal	Relay	A, B, C	Relay Output (Fault Output)	1 changeover contact output indicates that the inverter protective function has activated and the outputs are stopped. Fault: discontinuity across B and C (continuity across A and C), Normal: continuity across B and C (discontinuity across A and C)	Contact capacity: 240 VAC 2A (power factor = 0.4) or 30 VDC 1 A
Safety Stop Signal	SX1	Safety input (Channel 1)	Terminal functions can be selected using Pr.S051 SX1/SX2 terminal function selection.	For details, refer to the FR-E800-SCE Instruction Manual (Functional Safety).	
	SX2	Safety input (Channel 2)			
	SY1	Safety Output (Channel 1)	Terminal functions can be selected using Pr.S055 SY1/SY2 terminal function selection.		
	SY2	Safety Output (Channel 2)			
Common Terminal	SD	24 VDC Power Supply Common	Common output terminal for 24 VDC 0.1A power supply (terminal PC). Isolated from terminal 5.		
		External Transistor Common (Source (Positive Common))			
	PC	Safety Input Terminal Common	Common terminal for terminals SX1 and SX2.	Power supply voltage range: 22 to 26.5 VDC Permissible load current: 100 mA	
		24 VDC Power Supply	Can be used as a 24 VDC 0.1 A power supply.		
	5	Frequency Setting Common	Common terminal for the frequency setting signal (terminal 2 or 4). Do not earth (ground).		
	SC1	Safety Output Common (Channel 1)	For details, refer to the FR-E800-SCE Instruction Manual (Functional Safety).		
SC2	Safety Output Common (Channel 2)				
Communication	-	Ethernet Connector (2-Port) (*2)	Communication can be made via Ethernet. Category: 100BASE-TX/10BASE-T Transmission method: Baseband Data transmission speed: 100 Mbps (100BASE-TX) / 10 Mbps (10BASE-T) Maximum segment length: 100 m between the hub and the inverter Interface: RJ-45 Number of cascade connection stages: Up to 2 (100BASE-TX) / up to 4 (10BASE-T) Number of interfaces available: 2 IP version: IPv4		
	-	USB Connector (*3)	By connecting an inverter to the personal computer through USB, FR Configurator2 can be used for setting the inverter and monitoring the operation. Interface: conforms to USB 1.1 Transmission speed: 12 Mbps Connector: USB mini B connector (receptacle mini B type)		

### Notes:

- Terminal T/L3 is not available for the single-phase power input models.
- Do not connect the parameter unit. The inverter may be damaged.
- USB bus power connection is available. The maximum SCCR should be 500 mA.

# Outline Dimension Drawings

FR-E820-0.1K to 0.75K  
FR-E820S-0.1K to 0.4K

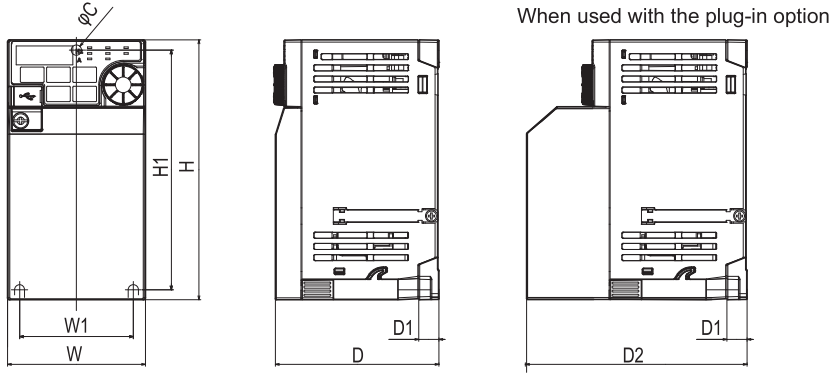

FR-E820-1.5K to 22K  
FR-E840-0.4K to 22K  
FR-E860-0.75K to 7.5K  
FR-E820S-0.75K to 2.2K

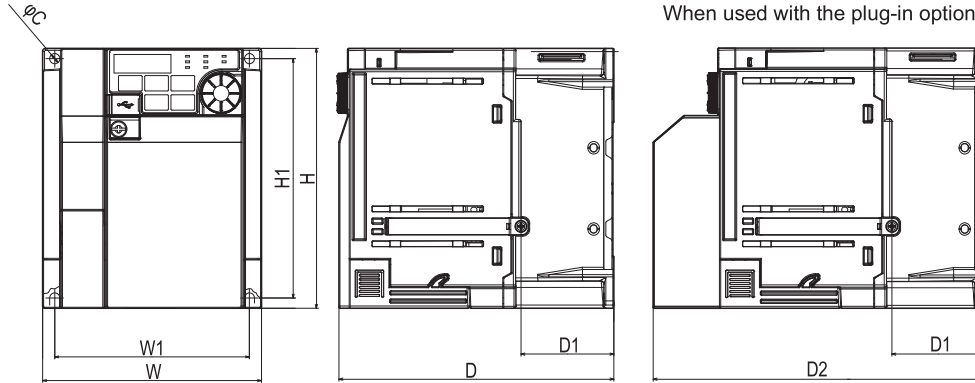

## Three-Phase 200V Class

Inverter Model	W	W1	H	H1	D	D1	D2	C
FR-E820-0.1K	68	56	128	118	80.5	10	108.1	5
FR-E820-0.2K					112.5	42	140.1	
FR-E820-0.4K					132.5	42	160.1	
FR-E820-0.75K					135.5	46	163.1	
FR-E820-1.5K					142.5	52.5	170.1	
FR-E820-2.2K	108	96	260	244	165	71.5	192.6	6
FR-E820-3.7K	140	128			190	84.7	217.6	
FR-E820-5.5K	180	164			190	84.7	217.6	
FR-E820-7.5K	220	195			190	84.7	217.6	
FR-E820-11K	220	200			350	330		

## Three-Phase 400V Class

Inverter Model	W	W1	H	H1	D	D1	D2	C
FR-E840-0.4K	108	96	128	118	129.5	40	157.1	5
FR-E840-0.75K					135	43.5	162.6	
FR-E840-1.5K					140	43.5	162.6	
FR-E840-2.2K	140	128	150	138	147	68	174.6	6
FR-E840-3.7K					190	84.7	217.6	
FR-E840-5.5K					190	84.7	217.6	
FR-E840-7.5K					190	84.7	217.6	
FR-E840-11K					220	195	260	

## Three-Phase 575V Class

Inverter Model	W	W1	H	H1	D	D1	D2	C
FR-E860-0.75K	140	128	150	138	135	43.5	162.6	5
FR-E860-1.5K					147	68	174.6	
FR-E860-2.2K					147	68	174.6	
FR-E860-3.7K					147	68	174.6	
FR-E860-5.5K					147	68	174.6	
FR-E860-7.5K	220	208						

## Single-Phase 200V Class

Inverter Model	W	W1	H	H1	D	D1	D2	C
FR-E820S-0.1K	68	56	128	118	80.5	10	108.1	5
FR-E820S-0.2K					142.5	42	170.1	
FR-E820S-0.4K					135	45.5	162.6	
FR-E820S-0.75K					161	46	188.6	
FR-E820S-1.5K					142.5	52.5	170.1	
FR-E820S-2.2K	140	128						

## DBR Pairings

Inverter Series [-5, -E, -SCE]	Resistor Model Number 10% Duty *(Parts in bold consist of a resistor pair that will need to be wired in parallel)*	Resistor Model Number 25% Duty *(Parts in bold consist of a resistor pair that will need to be wired in parallel)*	Resistor Model Number 33% Duty *(Parts in bold consist of a resistor pair that will need to be wired in parallel)*	Resistor Model Number 50% Duty *(Parts in bold consist of a resistor pair that will need to be wired in parallel)*
E820-0030	RFP-V-200-0030-10	RFP-V-200-0030-25	RFP-V-200-0030-33	RFP-V-200-0030-50
E820-0050	RFP-V-200-0050-10	RFP-V-200-0050-25	RFP-V-300-0050-33	RFP-V-400-0050-50
E820-0080	RFP-V-200-0080-10	RFP-V-200-0080-25	RFP-V-500-0080-33	<b>RFP-V-400-0080-50</b>
E820-0110	RFP-V-300-0110-10	<b>RFP-V-300-0110-25</b>	<b>RFP-V-400-0110-33</b>	CU-DB66D0-0110-50
E820-0175	RFP-V-400-0170-10	<b>RFP-V-500-0170-25</b>	CU-DB44D0-0170-33	CU-DB44D0-0170-50
E820-0240	<b>RFP-V-300-0020-10</b>	CU-DB28D0-0240-25	CU-DB28D0-0240-33	CU-DB28D0-0240-50
E820-0330	<b>RFP-V-400-0330-10</b>	CU-DB22D0-0330-25	CU-DB22D0-0330-33	CU-DB22D0-0330-50
E820-0470	CU-DB15D0-0470-10	CU-DB15D0-0470-25	CU-DB15D0-0470-33	CU-DB15D0-0470-50
E820-0600	CU-DB10D0-0600-10	CU-DB10D0-0600-25	CU-DB10D0-0600-33	CU-DB10D0-0600-50
E820-0760	CU-DB8D00-0760-10	CU-DB8D00-0760-25	CU-DB8D00-0760-33	CU-DB8D00-0760-50
E820-0900	CU-DB8D00-0900-10	CU-DB8D00-0900-25	CU-DB8D00-0900-33	CU-DB8D00-0900-50
E840-0016	RFP-V-400-0016-10	RFP-V-400-0016-25	RFP-V-400-0016-33	RFP-V-400-0016-50
E840-0026	RFP-V-300-0026-10	RFP-V-300-0026-25	RFP-V-300-0026-33	RFP-V-400-0026-50
E840-0040	RFP-V-300-0040-10	RFP-V-400-0040-25	RFP-V-500-0040-33	<b>RFP-V-400-0040-50</b>
E840-0060	RFP-V-300-0060-10	<b>RFP-V-400-0060-25</b>	<b>RFP-V-400-0060-33</b>	CU-DB0198-0060-50
E840-0095	RFP-V-400-0095-10	<b>RFP-V-500-0095-25</b>	CU-DB0143-0095-33	CU-DB0143-0095-50
E840-0120	<b>RFP-V-300-0120-10</b>	CU-DB0103-0120-25	CU-DB0103-0120-33	CU-DB0103-0120-50
E840-0170	<b>RFP-V-400-0170-10</b>	CU-DB74D0-0170-25	CU-DB74D0-0170-33	CU-DB74D0-0170-50
E840-0230	CU-DB54D0-0230-10	CU-DB54D0-0230-25	CU-DB54D0-0230-33	CU-DB54D0-0230-50
E840-0300	CU-DB40D0-0300-10	CU-DB40D0-0300-25	CU-DB40D0-0300-33	CU-DB40D0-0300-50
E840-0380	CU-DB29D0-0380-10	CU-DB29D0-0380-25	CU-DB29D0-0380-33	CU-DB29D0-0380-50
E840-0440	CU-DB29D0-0440-10	CU-DB29D0-0440-25	CU-DB29D0-0440-33	CU-DB29D0-0440-50
E820S-0030	RFP-V-200-S0030-10	RFP-V-200-S0030-25	RFP-V-200-S0030-33	RFP-V-200-S0030-50
E820S-0050	RFP-V-200-S0050-10	RFP-V-200-S0050-25	RFP-V-300-S0050-33	RFP-V-400-S0050-50
E820S-0080	RFP-V-200-S0080-10	RFP-V-400-S0080-25	RFP-V-500-S0080-33	<b>RFP-V-400-S0080-50</b>
E820S-0110	RFP-V-300-S0110-10	<b>RFP-V-300-S0110-25</b>	<b>RFP-V-400-S0110-33</b>	CU-DB66D0-0110-50
FR-E860-0017	RFP-V-300-385	RFP-V-300-385	RFP-V-300-385	RFP-V-400-385
FR-E860-0027	RFP-V-300-330	RFP-V-400-330	RFP-V-500-330	<b>RFP-V-500-660</b>
FR-E860-0040	RFP-V-300-286	<b>RFP-V-500-572</b>	<b>RFP-V-500-572</b>	CU-DB0286-0040-50
FR-E860-0061	RFP-V-400-209	<b>RFP-V-500-418</b>	CU-DB0209-0061-30	CU-DB0209-0061-50
FR-E860-0090	<b>RFP-V-300-308</b>	CU-DB0154-0090-25	CU-DB0154-009030	CU-DB0154-0090-50
FR-E860-0120	<b>RFP-V-400-220</b>	CU-DB0110-0120-25	CU-DB0110-0120-30	CU-DB0110-0120-50



# Options

Name	Type	Applications	Applicable Inverter			Remarks		
			E800	E800-E	E800-SCE			
Plug-In Type	Vector Control Orientation Control Encoder Feedback Control	FR-A8AP E Kit	Vector control can be performed for encoder-equipped motors (induction motors). The main spindle can be stopped at a specified position (orientation) in combination with an encoder. The motor speed is sent back and the speed is maintained constant.	○	○	○	Shared among all models	
	16-bit Digital Input	FR-A8AX E Kit	This input interface sets the high frequency accuracy of the inverter using an external BCD or binary digital signal. · BCD code 3 digits (maximum 999) · BCD code 4 digits (maximum 9999) · Binary 12 bits (maximum FFFF) · Binary 16 bits (maximum FFFFH)	●	●	○		
	Digital Output Extension Analog Output	FR-A8AY E Kit	This option provides the inverter with open collector outputs selected from among the standard output signals. This option adds 2 different signals that can be monitored such as the output frequency and output voltage. 20mADC or 10VDC meter can be connected.	●	●	○		
	Relay Output	FR-A8AR E Kit	Output any three output signals available with the inverter as standard from the relay contact terminals.	●	●	○		
	CC-Link Communication	FR-A8NC E Kit	This option allows the inverter to be operated or monitored or the parameter setting to be changed from a computer or programmable controller.	●	●	○		
	DeviceNet Communication	FR-A8ND E Kit		○	○	○		
	PROFIBUS-DP Communication	R-A8NP E Kit		○	○	○		
Stand-Alone Type	Liquid Crystal Display Operation Panel	FR-LU08 (-01)	Graphical operation panel with liquid crystal display	○	-	-	Shared among all models	
	Parameter Unit	FR-PU07	Interactive parameter unit with LCD display	○	-	-		
	Parameter Unit with Battery Pack	FR-PU07BB (-L)	This parameter unit enables parameter setting without connecting the inverter to power supply.	○	-	-		
	Enclosure Surface Operation Panel	FR-PA07	This operation panel enables inverter operation and monitoring of frequency, etc. from the enclosure surface	●	-	-		
	Parameter Unit Connection Cable	F R-CB20_	Cable for connection of operation panel or parameter unit _ indicates a cable length. (1m, 3m, 5m)	●	-	-		
	Encoder Cable Mitsubishi Electric Vector Control Dedicated Motor (SFV5RU)	FR-V7CBL_	Connection cable for the inverter and encoder for Mitsubishi Electric vector control dedicated motor (SFV5RU). _ indicates a cable length. (5m, 15m, 30m)	○	○	○		
	USB Cable	MR-J3USBCBL3M Cable Length: 3 m	Amplifier connector      Personal computer connector Mini B connector (5-pin)      A connector 	●	●	○		
	Intercompatibility Attachment	FR-E7AT 01/02/03	For installation of a FR-E800 series inverter to the installation holes of FR-A024/A044 series inverter.	●	●	○		3.7K or lower. The option's model varies with the inverter's model.
	Intercompatibility Attachment	FR-E8AT03	For installation of a FR-E700/E800 inverter to the installation holes of FR-A024/A044/E700 inverter.	●	●	○		3.7K
	DIN Rail Attachment	FR-UDA 01 to 03	Attachment for installation on DIN rail	○	○	○		3.7K or lower. The option's model varies with the inverter's model.
	Panel Through Attachment	FR-E8CN 01 to 06	Using this attachment dissipates the inverter's heat by having the inverter heatsink protrude from the back side of the enclosure.	○	○	○		All capacities. The option's model varies with the inverter's model.
	Totally Enclosed Structure Specification Attachment (IP40)	FR-E8CV 01 to 04	Installing the attachment to the inverter changes the protective structure of the inverter to the totally enclosed structure (IP40 equivalent as specified by JEM1030).	○	○	○		
AC Reactor	FR-HAL	For harmonic current reduction and inverter input power factor improvement	▲	▲	○			
DC Reactor	FR-HEL		▲	▲	○			
EMC Directive Compliant Noise Filter	SF, FR-E5NF, FR-S5NFSA	C Directive (EN 61800-3 C3) compliant noise filter	▲	▲	○			
EMC Compliant EMC Filter Installation Attachment	FR-A5AT03 FR-AAT02 FR-E5T(-02)	For installation of the inverter to the EMC Directive compliant EMC filter (SF).	▲	▲	○			

●: Supported ○: To be supported soon ▲: Supported (UL/cUL not yet met) -: Not Supported

## Options (CONTINUED)

	Name	Type	Applications	Applicable Inverter			Remarks
				E800	E800-E	E800-SCE	
Stand-Alone Type	Radio Noise Filter	FR-BIF(H)	For radio noise reduction (connect to the input side)	●	●	○	All capacities.
	Line Noise Filter	FR-BSF01 FR-BLF	For line noise reduction	●	●	○	
	Filterpack	FR-BFP2	Combination of power factor improving DC reactor, common mode choke, and capacitive filter	○	○	○	0.4K or higher of the three-phase power input model. The option's model varies with the inverter's model.
	Brake Resistor	MRS Type, MYS Type	For increasing the regenerative braking capability (permissible duty 3%ED)	●	●	○	0.4K or higher. The option's model varies with the inverter's model.
	High-Duty Brake Resistor	FR-ABR	For increasing the regenerative braking capability (permissible duty 10%/6%ED)	▲	▲	○	
	Brake unit, Resistor Unit, Discharging Resistor	FR-BU2, FR-BR, GZG, GRZG Type	For increasing the braking capability of the inverter (for high-inertia load or negative load) Brake unit, electrical-discharge resistor and resistor unit are used in combination	●	●	○	
	Multifunction Regeneration Converter Dedicated Stand-Alone Reactor Dedicated Box-Type Reactor	FR-XC FR-XCL/FR-XCG FR-XCB	One inverter can handle harmonic suppression and power regeneration. Functions that match the application can be selected by combining the inverter/converter with the dedicated reactor FR-XCB (box-type) or FR-XCL/FR-XCG.	●	●	-	According to capacities
	High Power Factor Converter	FR-HC2	The high power factor converter switches the converter section on/off to reshape an input current waveform into a sine wave, greatly suppressing harmonics. (Used in combination with the standard accessory.)	●	●	-	
Surge Voltage Suppression Filter	FR-ASF FR-BMF	Filter for suppressing surge voltage on motor	●	●	○		
Others	Pilot Generator	QVAH-10	For tracking operation. 70 V / 35 VAC 500 Hz (at 2500 r/min)	●	●	○	Shared among all models.
	Deviation Sensor	YVGC-500WNS	For continuous speed control operation (mechanical deviation detection) Output 90VAC /90°	●	●	○	
	Analog Frequency Meter (64mm x 60mm)	YM-206NRI 1mA	Dedicated frequency meter (graduated to 130 Hz). Moving-coil type DC ammeter	●	-	-	
	Calibration Resistor	RV24YN 10kΩ	For frequency meter calibration. Carbon film type B characteristic	●	●	○	
	FR Configurator2 (Inverter setup software)	SW1DND-FRC2	Supports an inverter startup to maintenance.	●	●	○	
	Configurator Mobile (Mobile App for Inverters)	-	The app enables operation of inverters using smart phones or tablets.	○	○	○	

●: Supported ○: To be supported soon ▲: Supported (UL/cUL not yet met) -: Not Supported

## Plug-In Options

Model Number	Description
FR-A8AX-60 E-KIT	16-BIT digital input option card kit
FR-A8NC-60 E-KIT	CC-LINK communication option card kit
FR-A8ND-60 E-KIT	DeviceNet communication option card kit
FR-A8AY-60 E-KIT	Digital/Analog output option card kit
FR-A8AP-60 E-KIT	Encoder/Vector control option card kit
FR-A8NP-60 E-KIT	Profibus communication option card kit
FR-A8AR-60 E-KIT	Relay Output option card kit

## Plug-In Options

Model Number	E820	E840	E860	E820S
FR-E8CN01	E820-0080/0110	-	-	E820S-0080
FR-E8CN02	E820-0175	-	-	E820S-0110
FR-E8CN03	E820-0240/0330	-	-	-
FR-E8CN04	-	E840-0040	-	-
FR-E8CN05	-	E840-0060/0095	E860-0027/0040	-
FR-E8CN06	-	E840-0120/0170	E860-0061/0090	-